

# ARES-100 Node

## Accelerometer-based 3D acoustic direction finding

ARES-100 Node is a new Acoustic Vector Sensor that uses an accelerometer to measure the motion of a small parcel of air in response to directional noise. In combination with a MEMS microphone, ARES-100 Node provides calibrated 3D acoustic particle velocity and pressure, both as a function of frequency. Azimuth and elevation angles are computed for multiple sources per time step. Multiple ARES Nodes, observing the same noise sources from different perspectives, can localize and track sources in space.

ARES-100 can serve as an accessory to a Sound Level Meter (SLM), providing measurement of directional bearings to acoustic events. This information increases the dimensionality of noise signatures, improving the confidence of autonomously characterized sound events.

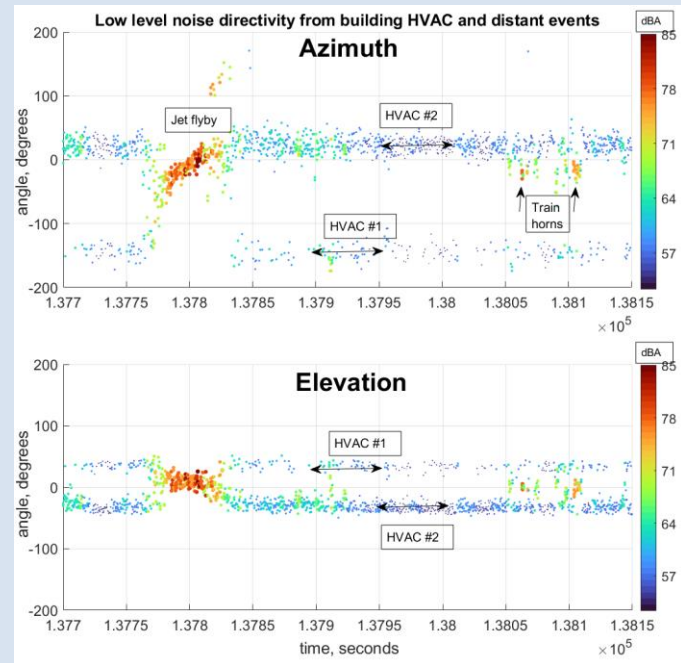

## SYNCHRONIZATION

GNSS enabled time synchronization is key to collaborative operation of ARES Nodes. All nodes within a single measurement session support synchronized sampling with  $< 1 \mu\text{sec}$  accuracy, independent of the distance between nodes. This also permits multiple nodes to be configured in arrangements that employ AVS beamforming.

## AUTONOMOUS MONITORING

The ability to measure directional noise enables autonomous acoustic monitoring, since noise sources outside of the monitored directions can be automatically excluded from the logged data. When coupled to an ARES Hub, acoustic events are detected and logged to a connected Amazon Web Services (AWS) IoT database. The same information can be logged to a Sound Level Meter, to facilitate autonomous noise characterization.

## TIME AND FREQUENCY

Pressure and acceleration are sampled in the time domain, and acoustic events optionally saved to the local SD card. All subsequent processing is in the frequency domain, including integration of acceleration to particle velocity, calculation of acoustic intensity (both active and reactive), and bearing angle measurements.

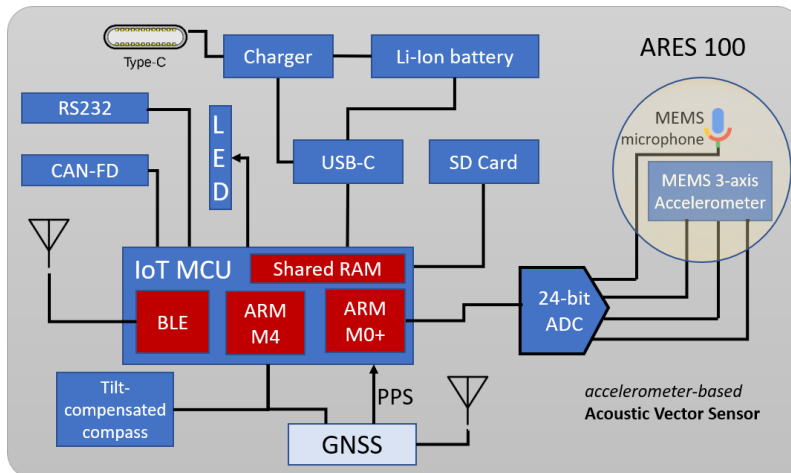

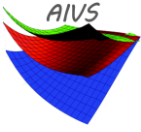

## ARES-100 Node Specifications v. 1.0

Frequency	
X, Y axes	100 Hz to 2 kHz Bins 4-80 (short FFT), or bins 24-480 (long FFT)
Z axis	100 Hz to 1.5 kHz Bins 4-60 (short FFT), or bins 24-360 (long FFT)
Sample rate	4800 Hz
FFT block size	Selectable short (192 points) or long (1152 points)
Frequency resolution	25 Hz or 4.16667 Hz
Window	Hann or Rectangular (none)
Time step	20 msec minimum
Event time window	Multiples of time step up to 1 second (50 time steps maximum)

Intensity Noise Floor	
100 Hz to 500 Hz	$30 + 4 \cdot (5 - \text{frequency}/100)$ dB re: 1 pW (low range)
500 Hz to 2000 Hz (X, Y)	30 dB re: 1 pW (low range)
500 Hz to 1500 Hz (Z)	30 dB re: 1 pW (low range)
For high accelerometer range, add 12 dB to above dB values	

GNSS	
Constellations	Concurrent reception of GPS, GLONASS, Galileo and BeiDou
Real-time kinematic corrections	Multi-band RTK with fast convergence times
Accuracy	With appropriate corrections, centimeter grade precision in a small and energy-efficient module
Pulse-per-Second (PPS)	24-bit ADC is disciplined by PPS, and synchronized to UTC time

Synchronization	
Auto sync	Upon PPS acquisition, ARES Node automatically synchronizes sampling to UTC time
Accuracy	< 1 $\mu$ s time base deviation between ARES Nodes
Manual sync	At any time, a group of ARES Nodes can be commanded to simultaneously reset sample counters to zero. This enables easy downstream cloud-based coordination of multi-node data, using the sync time as a dictionary key value.

Maximum Range (SPL)	
Low range	110 dB
High Range	122 dB

External Interfaces	
CAN-FD	4 Mbps high-speed synchronous transfers, 5-16 V power
Serial RS232	Programmable baud rates 9600 - 115200
Bluetooth Low Energy	1 Mbps wireless data transfer to Sound Level Meter or other clients
USB 2.0	USB-C serial communications

Orientation	
IMU	9 DOF inertial measurement unit, triaxial accelerometer, triaxial magnetometer, triaxial gyroscope.
Calibration	IMU is used to define ARES Node sensor frame with respect to a local geospatial Cartesian coordinate frame defined in Easting and Northing.
Accuracy	3° heading, 1° pitch and roll For improved heading accuracy (0.5°), use two ARES Nodes with the RTK option

Time Capture	
Rate	All 4 channels can be optionally recorded to SD card at a sample rate of 4800 Hz. New data files are generated automatically every hour.
Playback	Previously recorded time capture data can be processed in the same way as if live, generating velocity and pressure spectra as consumed by ARES App.
Backup	ARES Node SD card is not removable, so recorded files must be copied out over the CAN-FD bus to ARES Hub. The copy rate is approximately the same as real-time acquisition.

Wind Screen	
Material	Replaceable 105 $\mu$ m hydrophobic micromesh
Acoustic attenuation	< 1 dB

Environmental & Regulatory	
Operating Temperature	-20 - 60°C
Weather resistance	IP-65, sensor is encased in waterproof closed-cell foam
Certifications	FCC 47 CFR Part 15 CE WEEE Directive (2002/96/EC) Low Voltage Directive (2014/35/EU) Electromagnetic Compatibility Directive (2014/30/EU) RoHS 3 (2015/863/EU) REACH IEC 61010 (Measurement Equipment) IEC 62133 (Batteries)

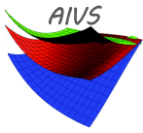

## ARES-100 Node Specifications v. 1.0

### Example output – JSON message

ARES-100 nodes output bearing results as JSON formatted strings after every event time window. Time is in POSIX milliseconds, SPL in dBA. Azimuth and Elevation for one or more detected sources are in degrees relative to accelerometer coordinates. The shaded lines in the example below shows the highest three noise sources per the selected 800 millisecond event time window, for the right-most train horn event shown in the graph on the first page. Pressure (“pres”) is the average over the selected event time window for the maximal angular bin. Each pressure or intensity increment to the angular event histogram can arise from any spectral bin. So, the overall pressure, and active and reactive radial intensities to the source (“pres”, “acti”, and “reac”) are meaningful only in relation to each other, but can be used as a confidence check on the bearing data.

```
{
  "time": 1691326422400, "sync": 1691188320000, "node": 5, "spl": 54.5, "azim": -143.8, "elev": -37.5, "pres": 52.7, "acti": 47.5, "reac": 44.5}
{"time": 1691326422400, "sync": 1691188320000, "node": 5, "spl": 54.5, "azim": 16.3, "elev": 31.7, "pres": 52.9, "acti": 44.7, "reac": 43.6}
{"time": 1691326422400, "sync": 1691188320000, "node": 5, "spl": 54.5, "azim": 63.3, "elev": 40.3, "pres": 50.1, "acti": 44.6, "reac": 43.6}
{"time": 1691326423200, "sync": 1691188320000, "node": 5, "spl": 54.5, "azim": -153.4, "elev": -42.9, "pres": 47.6, "acti": 46.2, "reac": 39.7}
{"time": 1691326423200, "sync": 1691188320000, "node": 5, "spl": 54.5, "azim": 41.3, "elev": 30.9, "pres": 52.3, "acti": 43.9, "reac": 39.9}
{"time": 1691326424000, "sync": 1691188320000, "node": 5, "spl": 60.8, "azim": -17.8, "elev": 4.1, "pres": 65.1, "acti": 52.4, "reac": 50.3}
{"time": 1691326424000, "sync": 1691188320000, "node": 5, "spl": 60.8, "azim": -7.0, "elev": 15.5, "pres": 63.0, "acti": 51.7, "reac": 48.3}
{"time": 1691326424000, "sync": 1691188320000, "node": 5, "spl": 60.8, "azim": -3.0, "elev": 10.8, "pres": 61.8, "acti": 50.5, "reac": 48.0}
{"time": 1691326424800, "sync": 1691188320000, "node": 5, "spl": 61.4, "azim": -15.0, "elev": -4.7, "pres": 64.8, "acti": 53.7, "reac": 51.7}
{"time": 1691326424800, "sync": 1691188320000, "node": 5, "spl": 61.4, "azim": -12.3, "elev": -1.8, "pres": 62.7, "acti": 52.8, "reac": 49.3}
{"time": 1691326424800, "sync": 1691188320000, "node": 5, "spl": 61.4, "azim": -9.9, "elev": 6.5, "pres": 63.5, "acti": 52.7, "reac": 51.3}
{"time": 1691326425600, "sync": 1691188320000, "node": 5, "spl": 59.5, "azim": -30.2, "elev": -7.7, "pres": 59.0, "acti": 53.7, "reac": 50.6}
{"time": 1691326425600, "sync": 1691188320000, "node": 5, "spl": 59.5, "azim": -19.2, "elev": -4.7, "pres": 66.7, "acti": 53.6, "reac": 51.5}
{"time": 1691326425600, "sync": 1691188320000, "node": 5, "spl": 59.5, "azim": -28.9, "elev": -5.3, "pres": 62.4, "acti": 53.3, "reac": 50.8}
{"time": 1691326426400, "sync": 1691188320000, "node": 5, "spl": 56.6, "azim": 10.9, "elev": 43.8, "pres": 51.7, "acti": 46.3, "reac": 44.9}
{"time": 1691326426400, "sync": 1691188320000, "node": 5, "spl": 56.6, "azim": -35.9, "elev": -7.5, "pres": 48.6, "acti": 44.6, "reac": 40.7}
{"time": 1691326426400, "sync": 1691188320000, "node": 5, "spl": 56.6, "azim": -143.2, "elev": -31.2, "pres": 53.1, "acti": 44.4, "reac": 41.6}
```

### ARES Node Dimensional Drawing

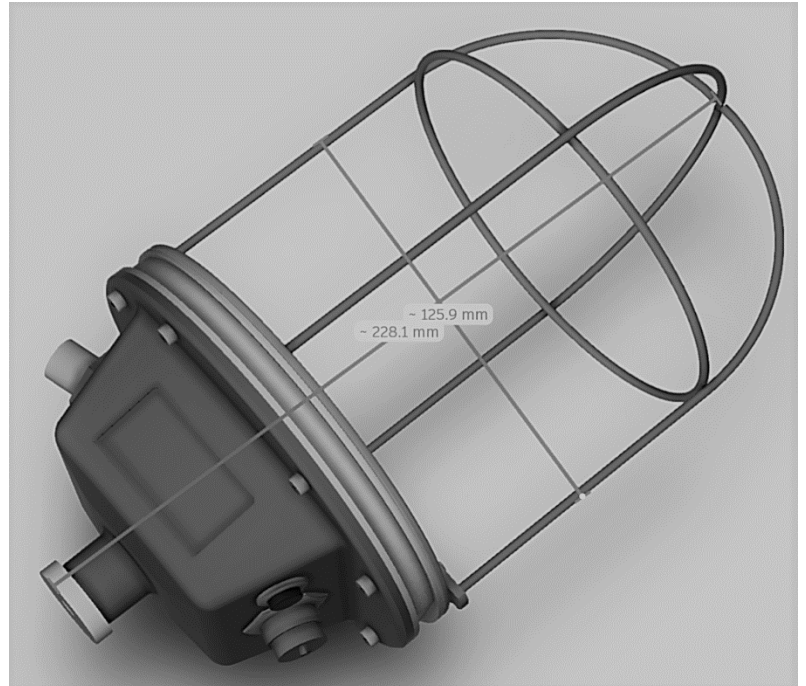

ARES nodes include a 1/4"-20 female tripod adapter, which can be removed to permit coupling to the male thread of a 5/8"-11 survey rod.